

CİHAZ TİPİ: LS ELECTRIC, M100 - HIZLI DEVREYE ALMA PARAMETRELERİ

Par. No	Değeri	Birim	Açıklama
OGR	1		Tüm parametreleri görme yetkisi aktif(Ana ekranda aşağı ok tuşuna basın)
CF 93	1		Parametreleri sıfırlama
ACC	20-60	sn.	Rampa 1 Hızlanma süresi (Motor gücüne göre rampalar artırılmalıdır)
dEC	20-60	sn.	Rampa 1 Yavaşlama süresi (Motor gücüne göre rampalar artırılmalıdır)
drv			Kumanda Kaynağı 0=Keypad, 1=Terminal, 3=Haberleşme
Frq			Frekans Kaynağı 0= Keypad, 2= Cihaz Üzerindeki Dahili Potans Terminal, 3= V1 Terminal, 4= I2 Terminal, 9= Haberleşme
dr 11	Hz.	JOG frekansı
MbF	50	Hz.	Besleme (Base) frekansı
FrM	50	Hz.	Maksimum frekans
Ad 10	1		Enerji kesintisinden sonra otomatik çalışma, 0=kapalı, 1=açık
Ad 24			Frekans limitleme , 0= Kapalı, 1= Açık (Min-Maks frekans belirlemek için açık olmalıdır)
Ad 25		Hz.	Minimum frekans (Asenkron motorlarda düşük devir çalışmak zararlıdır.Min 20Hz önlr.)
Ad 26		Hz.	Maksimum frekans
Ad 51		%	Enerji tasarrufu operasyonu (0-30%) (SERVİSE DANIŞMADAN AÇMAYINIZ!!!)
Ad 68			Sürücü soğutma fanı çalışma durumu 0=start komutu gelince, 1= her zaman, 2= sıcaklığa göre
PR 5			Çıkış faz kaybı hatası 0=No, 1=Yes
PR 8			Otomatik Hata Resetleme Fonksiyonu 0=No, 1=Yes
PR 9	0-10		Otomatik Hata Resetleme Deneme Sayısı (0-10 arası değer girilebilir)
PR 10	0.0 - 60.0	sn.	Otomatik Hata Resetleme Denemeleri Arasındaki Süre (Önerilen 5.0 sn.)
PR 50	010		Aşırı akımı engellemek için rampa uzatma fonksiyonu (Çizgi yukarda ise 1, aşağıda ise 0 durumunu temsil eder. Belirtilen 010 bit durumunu seçiniz)
Cn 71	b1111		Flying start (dönen motoru yakalama) aktif (Bit durumlarıdır.)
Cn 72	100	%	Flying start (dönen motoru yakalama) frekans arama akım değeri
In 8	0	V.	V1 nolu Analog Giriş; minimum voltaj 0V
In 10	10	V.	V1 nolu Analog Giriş; maksimum voltaj 10V
In 38	0	V.	V0 nolu Analog Giriş; minimum voltaj 0V
In 40	10	V.	V0 nolu Analog Giriş; maksimum voltaj 10V
In 53	4	mA	I nolu Analog Giriş; minimum akım
In 55	20	mA	I nolu Analog Giriş; maksimum akım
MkW		Kw.	Nominal motor gücü
bA 7			0=Lineer Eğri, 1=Parabolik Eğri
bA 11			Motor Kutup Sayısı
MrC	A.	Nominal motor akımı
IOv	V.	Nominal Motor Voltajı
bA 19	V.	Sürücü Besleme Voltajı (Daha doğru motor kontrolü için ölçüm sonucunu yazınız)
In 65			Terminal P1 Dijital Giriş: 0 İleri Yön Start
In 66			Terminal P2 Dijital Giriş: 1 Geri Yön Start
In 67			Terminal P3 Dijital Giriş: 2 Acil Stop (NC bekler)
In 68			Terminal P4 Dijital Giriş: 3 Hata Reset
In 69			Terminal P5 Dijital Giriş: 4 Düşük Hız (Speed-L)
Röle İşlevleri	OUT 31	Röle-1 İşlevi	17= Dış Hata 6= invertör Aşırı Yük 5= Aşırı Yükleme(OL) 12= Start 13=Stop 14= Sabit Hızda 15= Hız Arama 16= Sürücü Hazır 18= Anormal soğutma fanı alarmı 19=Fren sinyali ayarı

LS ELECTRIC M100 GÜÇ VE KUMANDA BAĞLANTISI

0.1-0.2 kW (Single Phase)

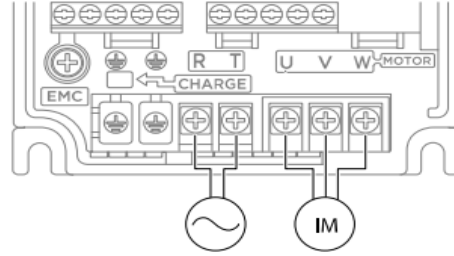

1-phase AC Input Motor

0.4-0.75 kW (Single Phase)

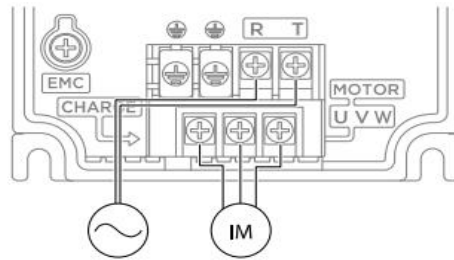

1-phase AC Input Motor

1.5-2.2 kW (Single Phase)

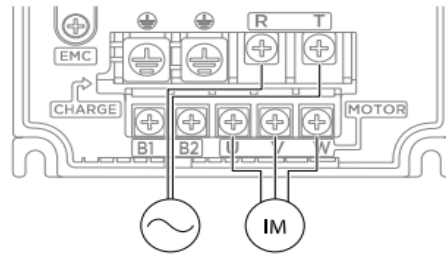

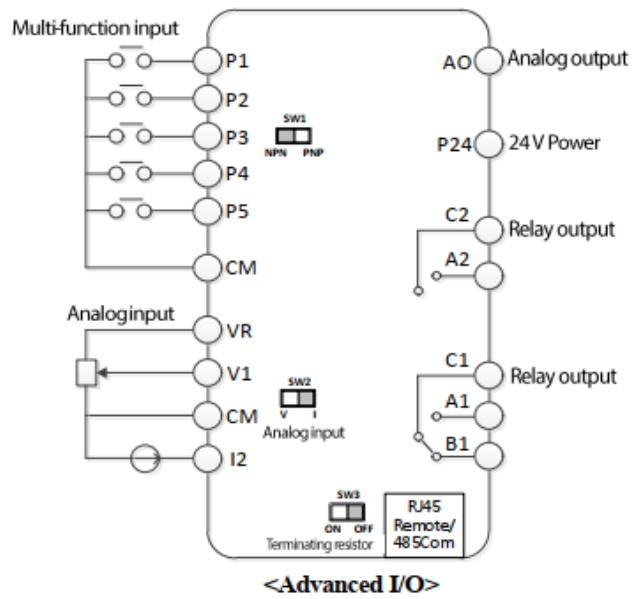
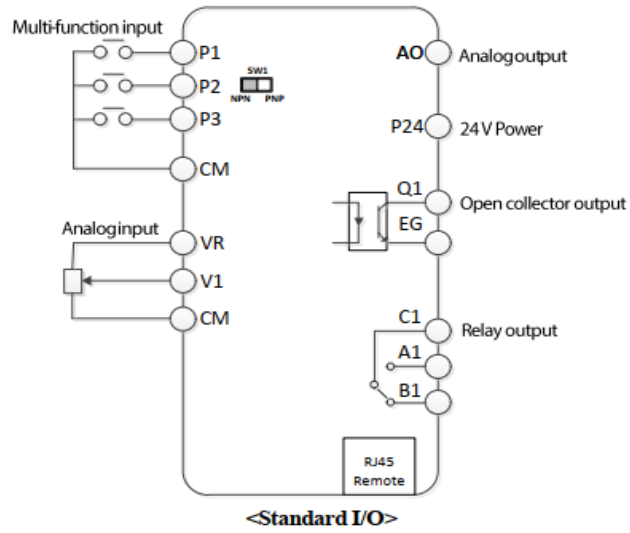

1-phase AC Input Motor

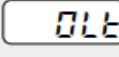
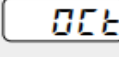
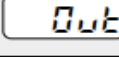
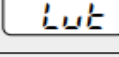
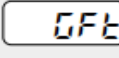
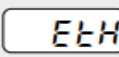
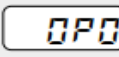
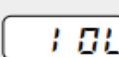
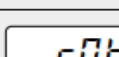

LS ELECTRIC M100 HATA MESAJLARI

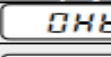
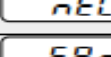
Keypad Display	Item	Type	Description
	OLt (Over Load)	Latch	Displayed when the motor overload trip is activated and the actual load level exceeds the set level. Operates when Pr20 is set to a value other than 0.
	OCt (Over Current)	Latch	Displayed when inverter output current exceeds 200% of the rated current.
	OVt (Over Voltage)	Latch	Displayed when internal DC circuit voltage exceeds the specified value.
	LVt (Low Voltage)	Level	Displayed when internal DC circuit voltage is less than the specified value.
	GFt (Ground Trip)	Latch	Displayed when a ground fault trip occurs on the output side of the inverter and causes the current to exceed the specified value. The specified value varies depending on inverter capacity.
	EtH (E-Thermal)	Latch	Displayed based on inverse time-limit thermal characteristics to prevent motor overheating. Operates when Pr40 is set to a value other than 0.
	OPO (Out Phase Open)	Latch	Displayed when a 3-phase inverter output has one or more phases in an open circuit condition. Operates when bit 1 of Pr05 is set to 1.
	IOL (Inverter OLT)	Latch	Displayed when the inverter has been protected from overload and resultant overheating, based on inverse time-limit thermal characteristics. Allowable overload rate for the inverter is 150% for 1 min.
	rOt	Fatal	Displayed when the input power is unstable or an initial charging circuit trip occurs while supplying power to the inverter. ¹⁾²⁾

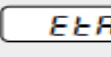
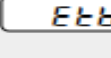
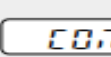
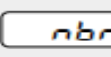
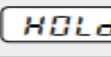
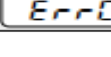
Keypad Display	Item	Type	Description
	Oht (Over Heat)	Latch	Displayed when the temperature of the inverter heat sink exceeds the specified value.
	ntC (NTC Open)	Latch	Displayed when an error is detected in the temperature sensor of the Insulated Gate Bipolar Transistor (IGBT).
	FAn (Fan Trip)	Latch	Displayed when an error is detected in the cooling fan ²⁾ .
 	EtA,EtB (External Trip A,B)	Latch	When the multi-function input terminal of the I/O is set to EtA or EtB, the input terminal is used as the signal. <ul style="list-style-type: none"> EtA is displayed when the CM and short signal are generated when the multi-function input is NPN or P24 and the short signal is generated when multi-function input is PNP. EtB is displayed when the CM and open signal are generated when multi-function input is NPN or P24 and open signal is generated when multi-function input is PNP.
	COM (Communication trip)	Latch	Displayed when communication between the Main DSP and the IO CPU is disconnected for more than 500 ms.
	nbr	Latch	Displayed when the inverter's output current is below the value set at Ad41 during the external brake signal operation based on the multi-function terminal function setting. Set OU31 or OU32 to 19 (Brake signal setting).
	IO Board Trip	Latch	Displayed when supplying power to the inverter and continuously displayed when communication is disconnected after supplying power.
			Displayed when communication is disconnected for more than 2 seconds after connected normally.