

User Manual

**4.2KVA/ 7.0KVA
INVERTER / CHARGER**

Table Of Contents

ABOUT THIS MANUAL	3
Purpose	3
Target Group	3
SAFETY REGULATIONS	3
INTRODUCTION	4
Features	4
Basic System Architecture	4
Product Overview	5
INSTALLATION	6
Unpacking And Inspection	6
Preparation Before Installation	6
Installation	6
Battery Connection	7
Lead-Acid Battery Connection	7
Lithium Battery Connection	8
AC Input/Output Connection	12
PV Connection	14
Final Assembly	15
OPERATION	15
Power On/Off	15
Operation And Display	16
RGB Light (optional)	16
Status Indicator	16
Function Key	16
Icon Of LCD Display	16
LCD Setting	17
LCD Display Information	24
Operation Mode Description	26
Fault Code	28
Warning code	29
BATTERY EQUALIZATION	29
SPECIFICATIONS	31
Table 1 Specification of LINE Mode	31
Table 2 Specification of Inverter Mode	32
Table 3 Double Load Output Power	32
Table 4 Specification of Charging Mode	33
Table 5 General specifications	33
TROUBLE SHOOTING	34

ABOUT THIS MANUAL

Purpose

This manual introduces the assembly, installation, operation and troubleshooting of inverter. Please read this manual carefully before installation and operation.

Target Group

This manual is designed for professionals and end users. Operations that do not require any specific skills can also be handled by the end users themselves. Professionals must have the following skills:

- Understand how the inverter works and operates
- After training, someone knows that how to deal with crises and risks in the installation and use of electrical equipment and devices
- After training, someone knows that how to install and commission electrical equipment and fixtures
- Understand the applicable standards and directives
- Understand and abide by this manual and all safety knowledge

SAFETY REGULATIONS



Warning: This article contains important safety and operation instructions. Please read and save this manual for future reference.

1. Please choose the corresponding setting according to whether to use lead-acid battery or lithium battery. If it is not set properly, the system may not operate normally.
2. Before using the unit, please read all the instructions and cautionary on the unit and understand all battery models and relevant chapters in this manual.
3. Never short-circuit AC output and DC input. Never connect the mains when the DC input is short-circuited.
4. Never charge a non-rechargeable battery.
5. Do not disassemble the unit. When maintenance or repair is needed, please send it to the professional technical service center. Incorrect reassembly may lead to electric shock or fire.
6. To reduce the risk of electric shock, disconnect all wiring before attempting any maintenance or cleaning. Turning off the device will not reduce this risk.
7. Be extra careful when using metal tools on or around the battery. Some potential risks, such as short circuit of batteries or other electronic components caused by sparks caused by falling tools, may lead to explosion.
8. In order to realize the optimal operation of this off grid solar inverter, please select the appropriate cable size according to the instruction. It is very important to operate the off grid solar inverter correctly.
9. When disconnecting AC or DC terminals, please strictly follow the installation procedure. For more details, please refer to "Installation" in this manual.
10. Grounding instruction this off grid solar inverter shall be connected to the permanent grounding wiring system. Be sure to comply with local requirements and regulations to install this inverter.
11. Provide a fuse that meets certain specifications for battery power supply as overcurrent protection.
12. **Warning!** Only professional service personnel can repair this equipment. If there are

still errors after troubleshooting, please send this off line solar inverter back to the local dealer or service center for maintenance.

INTRODUCTION

This is a multifunctional off grid solar inverter, which integrates MPPT solar charging controller, high-frequency pure sine wave inverter and UPS function module, and is very suitable for off-grid backup power supply and spontaneous self-use system. The design of high-frequency transformer enables the machine to provide reliable power conversion in a small size. This inverter can also work in battery-free mode.

The whole system also needs other equipment to achieve complete operation, such as photovoltaic modules, generator or utility grid. According to your requirements, please consult your system integrator to obtain other possible system components. WiFi module is a plug-and-play monitoring device installed on the inverter. With this device, users can monitor the running status of solar system anytime and anywhere through mobile phones or websites.

Features

- Pure sine wave output inverter
- According to the requirements of load (household appliances/personal computers), the input voltage range of utility grid can be selected
- According to the battery requirements, the charging current can be set through LCD
- Solar energy and utility grid can power loads at the same time
- AC input is compatible with mains and generator
- This unit have two AC outputs, one connected to the main load and the other to the emergency standby load
- Automatic restart function when mains power is restored
- Overload/ Over temperature/ short circuit protection
- The intelligent charging design of battery makes the battery more fully utilized
- Cold start function
- RS485 is used to communicate with BMS and adjust the charging current of inverter according to battery demand
- It can work with or without batteries
- Intelligent fan speed adjustment, which adjusts the fan speed according to temperature, load and charging current
- Built-in MPPT, operating voltage range 55V~430V, open circuit voltage 450Voc
- RGB lamp, which displays different colors according to inverter status
- WIFI remote monitoring (optional)
- Equip with clock, you can set the AC charge time/ utility source to take Load time, Meanwhile also count the solar power generation
- Offline upgrade function, firmware can be upgraded through COM port
- Grid-connected

Basic System Architecture

The following illustration shows basic application for this inverter/charger. It also includes following devices to have a complete running system:

- Generator or mains electricity
- Solar module (optional)

Consult with your system integrator for other possible system architectures depending on your requirements. This inverter can power all kinds of appliances in home or office environment, including motor type appliances such as tube light, fan, refrigerator and a ir

conditioner.

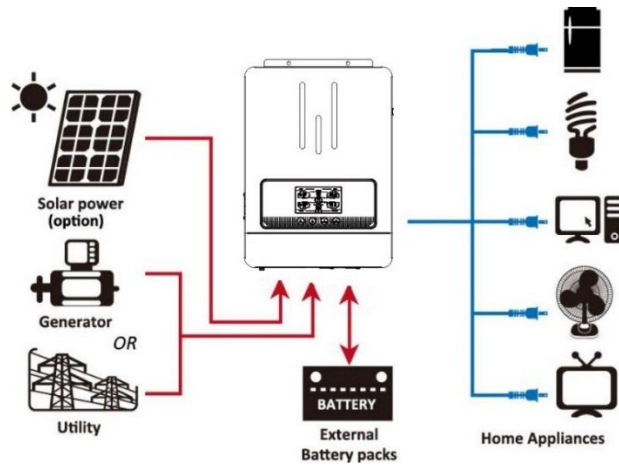

Product Overview

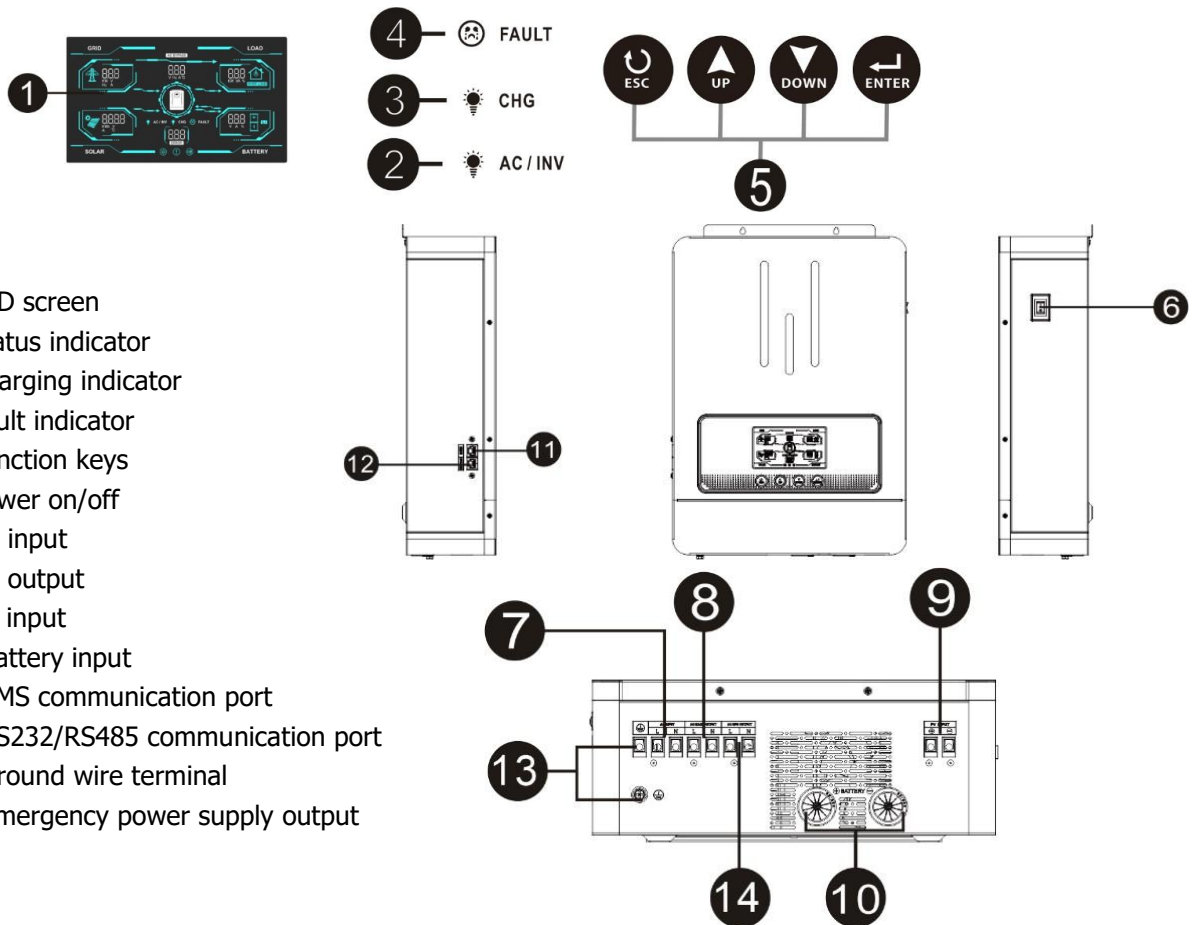

1. LCD screen
2. Status indicator
3. Charging indicator
4. Fault indicator
5. Function keys
6. Power on/off
7. AC input
8. AC output
9. PV input
10. Battery input
11. BMS communication port
12. RS232/RS485 communication port
13. Ground wire terminal
14. Emergency power supply output

INSTALLATION

Unpacking And Inspection

Unpack the inverter and make sure there are no damaged objects in the package. You should have received the following items inside of package:

- Machine x 1
- User manual x 1

Preparation Before Installation

Before connecting all wirings, please take off bottom cover by removing two screws as shown below.

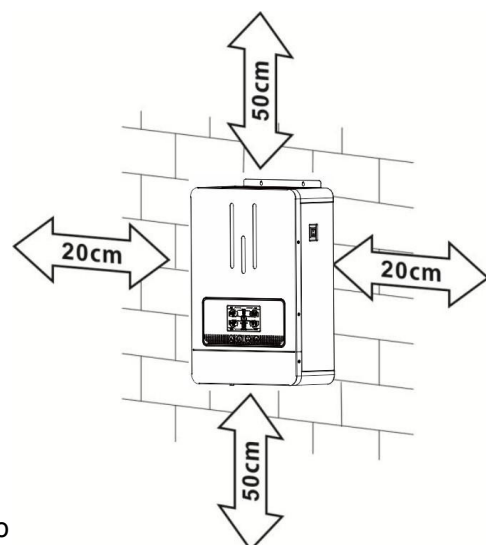
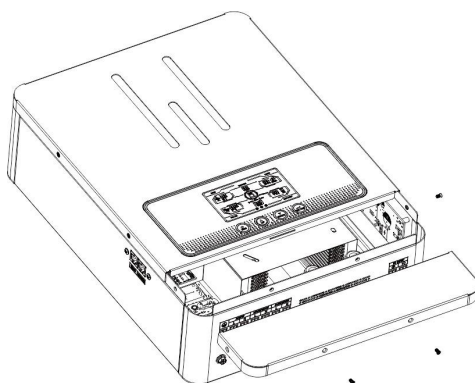

Installation

Please consider the following points before installing the equipment:

1. Do not install the inverter on flammable building materials;
2. Install on a solid surface;
3. Install this inverter at eye level in order to allow the LCD display to be read at all times;
4. Leave a gap of 20-50 cm for ventilation and heat dissipation of the equipment;
5. The equipment working environment temperature should be 0-55°C;
6. It is the best to install it vertically down against the wall, leaving a certain space with the ground.



SUITABLE FOR INSTALLATION ON CONCRETE OR OTHER NON-COMBUSTIBLE SURFACE ONLY

Tighten the screws and fix the installation. Machine fixing screws: M4 or M5 screws are recommended.

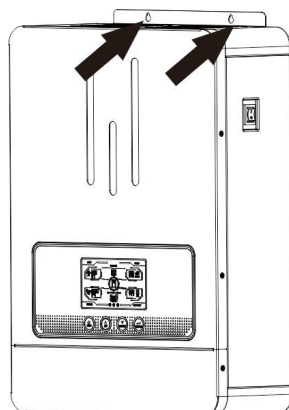

Battery Connection

Lead-Acid Battery Connection

WARNING: In order to operate safely and comply with laws and regulations, it is required to install an independent DC overcurrent protector or disconnect device between the battery and the inverter.

WARNING: All wiring must be performed by a qualified personnel.

WARNING: It's very important for system safety and efficient operation to use appropriate cable for battery connection. To reduce risk of injury, please use the proper recommended cable and as below.

Recommended battery cable specifications:

Model	Wire specification		Torque value
4.2KVA-24V	1 * 2 AWG	34mm ²	2-3 Nm
7KVA-48V	1 * 4 AWG	22mm ²	2-3 Nm



Note: The recommended charging current of lead-acid battery is 0.2C (C is battery capacity).

Please follow below steps to implement battery connection:

1. Connect the battery according to the recommended battery cable specifications.
2. Connect all battery packs as needed.
3. Insert the ring terminal of the battery cable into the battery connector of the inverter flatly, and ensure that the bolts are tightened with a torque of 2-3 Nm. Make sure that the polarities of the battery and inverter are connected correctly, and tighten the ring terminal with the battery terminal.

	WARNING: Shock Hazard Installation must be performed with care due to high battery voltage in series.
	CAUTION! ! Do not place anything between the flat part of the inverter terminal and the ring terminal, otherwise, It may cause short circuit or overheating.
	CAUTION! ! Do not apply antioxidant to the terminal before it is tightly connected.
	CAUTION! ! Before making the final DC connection or closing DC breaker/disconnector, be sure positive (+) must be connected to positive (+) and negative (-) must be connected to negative(-).

4. Connect all battery packs in the following table.

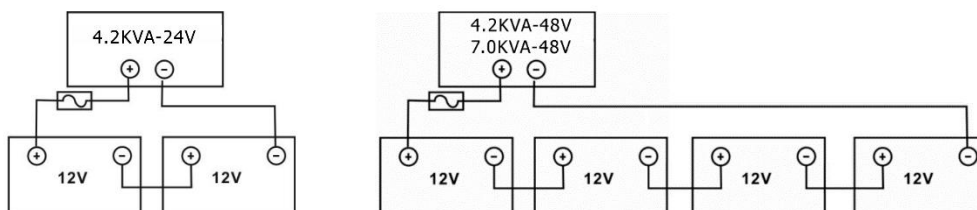

Lithium Battery Connection

If choosing lithium battery for the inverter, only lithium batteries that have been matched with BMS communication protocol are allowed.

1. Connect the battery according to the recommended battery cable specifications.
2. Insert the ring terminal of the battery cable into the battery connector of the inverter flatly, and ensure that the bolts are tightened with a torque of 2-3 Nm. Make sure that the polarities of the battery and inverter are connected correctly, and that the ring terminal is tightened with the battery terminal.
3. Connect one side of RJ45 cable to the BMS communication port of inverter.
4. Insert the other side of RJ45 cable into RS485 communication port on lithium battery.

Note: If you choose a lithium battery, please make sure to connect the battery and inverter with BMS communication cable, and select the battery type as "LIB-485" mode.

Communication And Setting Of Lithium Battery

1. Connect the RJ45 communication cable between inverter and battery. Please confirm that the lithium battery BMS port's PIN is correspond with the inverter BMS communication port. The inverter BMS port's PIN definition as below:

Pin number	Port definitions
1	RS485B
2	RS485A
3	NG
4	NG
5	NG
6	NG
7	RS485A
8	RS485B

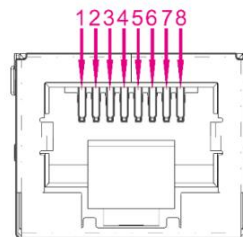

2. In order to communicate with the lithium battery BMS, you should press the "ENTER" button for a long time, and set the battery type as "LIB-485" in program 05. Then select the matching battery protocol in Program 10 .

05	Battery type	AGM (default) 05 <u>AGm</u>
		Flooded 05 <u>FLd</u>
		User Defined 05 <u>USE</u>
		Lithium battery mode 05 <u>LIb</u>
		Lithium battery communication mode LIb 05 <u>485</u>
10	Lithium battery protocol	PYLON 10 <u>PYL</u>

		PACE 10 PRC
--	--	----------------

CAUTION: When the battery type is set to "LIB-485", the setting items 12, 13 and 29 are displayed in percentage.

CAUTION: When the battery type is set to "LIB-485", the user cannot modify the maximum charging current. When communication fails, the inverter will cut off the output.

12	When the SBU mode is selected in program 01, the battery SOC point for switching to the utility source input can be set.	12 50% The default value is 50%, and 10% ~ 50% can be set.
13	When the SBU mode is selected in program 01, the SOC point for switching to the battery mode can be set.	13 95% The default value is 95%, and 30% ~ 100% can be set.
29	If "LIB-485" is selected in item 05. you can set the battery low SOC shutdown point.	29 20% The default value is 20%, and 5% ~ 30% can be set.



3. In "LIB-485" mode, press and hold the "ESC" button to view the information of the lithium battery, and the inverter display screen will enter the following screen (the initial interface shows the total battery voltage and remaining battery capacity).



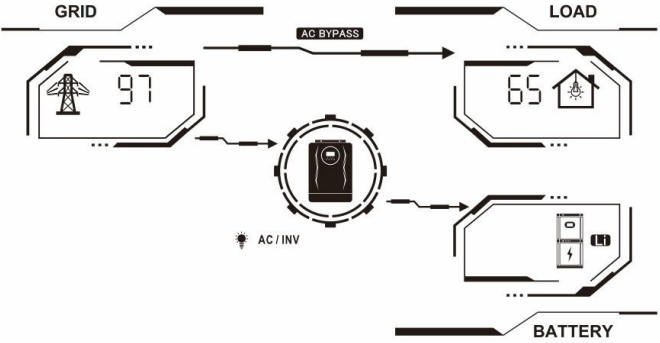
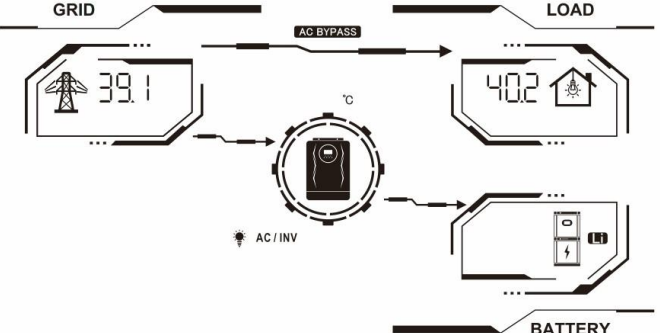
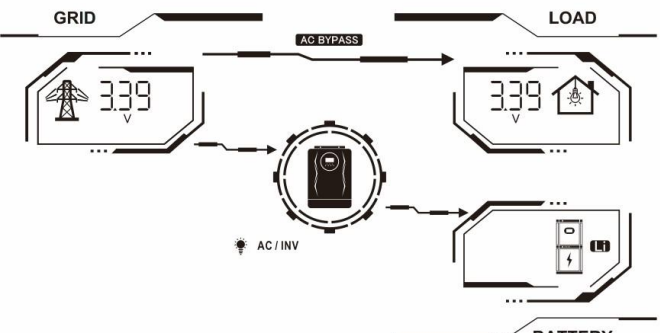
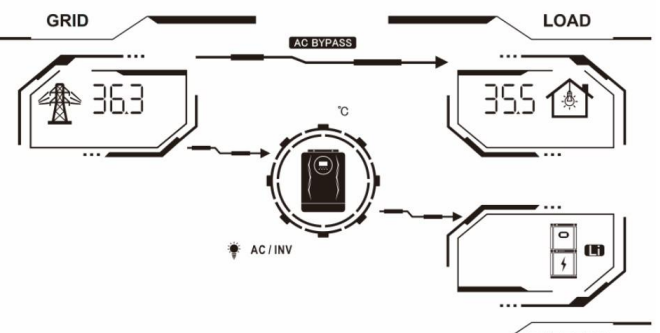







Press the "DOWN" button to display the following data in turn.

Battery voltage 27.1V The remaining battery capacity is 77%	
Battery charging current 46A Battery discharge current 0A	













<p>The rated capacity of the battery is 97AH. Cycle charge and discharge times is 65 times</p>	
<p>BMS board temperature 39.1°C MOS temperature 40.2°C</p>	
<p>The maximum voltage of single battery cell is 3.39V. The minimum voltage of single battery cell is 3.39V</p>	
<p>The maximum temperature of single battery cell is 36.3°C The minimum temperature of single battery cell is 35.5°C</p>	











Battery Alarm Code

Alarm code	Alarm event	Icon flashing
21	Battery Cell Over Voltage	
22	Battery Cell Under Voltage	
23	Battery Pack Over Voltage	

24	Battery Pack Under Voltage	
25	Charging Over Current	
26	Discharging Over Current	
27	Charging Cell Over Temperature	
28	Discharging Cell Over Temperature	
29	Charging Cell Under Temperature	
30	Discharging Cell Under Temperature	
34	Battery capacity is too low	
44	Battery Cell Voltage Imbalance	
45	Battery Cell Temperature Imbalance	
46	Internal Communication Alarm	

Battery fault code

Fault code	Fault event	The icon is long and bright
21	Battery Cell Over Voltage	
22	Battery Cell Under Voltage	
23	Battery Pack Over Voltage	
24	Battery Pack Under Voltage	
25	Charging Over Current	
26	Discharging Over Current	
27	Charging Cell Over Temperature	
28	Discharging Cell Over Temperature	
29	Charging Cell Under Temperature	
30	Discharging Cell Under Temperature	
31	Ambient Over Temperature	
32	Ambient Under Temperature	

33	MOS Over Temperature	
35	Battery Short Circuit	
36	Charge Overvoltage	
37	System Failure	
39	Charging MOS Fault	
40	Discharge MOS Fault	
41	Temperature Sensor Fault	
42	Battery Cell Fault	
43	Sampling Communication Failure	
61	Communication Failure	

AC Input/Output Connection

CAUTION! ! Before connecting to AC input power source, please install a separate AC breaker between inverter and AC input power source. This will ensure the inverter can be securely disconnected during maintenance and fully protected from over current of AC input.

CAUTION! ! There are two terminal blocks with "IN" and "OUT" markings. Please do NOT misconnect input and output connectors.

WARNING! ! All wiring must be performed by a qualified personnel.

WARNING! ! It's very important for system safety and efficient operation to use appropriate cable for AC input connection. To reduce risk of injury, please use the proper recommended cable size as below.

Suitable cable specifications for AC wires

Model	Wire Gauge	Torque Value
4.2KVA-24V	1 * 10 AWG	1.2-1.6 Nm
7KVA-48V	1 * 8 AWG	1.2-1.6 Nm

Please follow below steps to implement AC input/output connection:

1. Before making AC input/output connection, be sure to open DC protector or disconnect first.
2. Remove insulation sleeve 10mm for six conductors. And shorten phase L and neutral conductor N 3 mm.
3. Insert AC input wires according to polarities indicated on terminal block and tighten the terminal screws. Be sure to connect PE protective conductor () first.

 → Ground (yellow-green)

L → LINE (brown or black)

N → Neutral (blue)

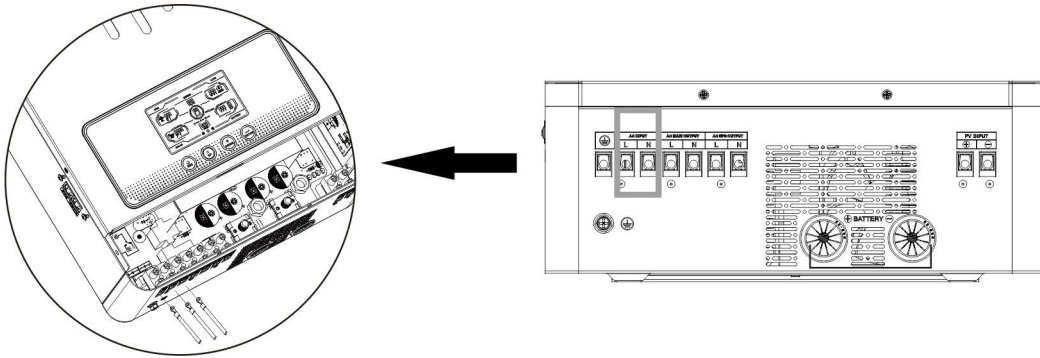

WARNING:

Be sure that AC power source is disconnected before attempting to hardwire it to the unit.

4. Then, insert the AC output conductor according to the polarity identification at the terminal, and tighten the screw.

L → LINE (brown or black)

N → Neutral (blue)

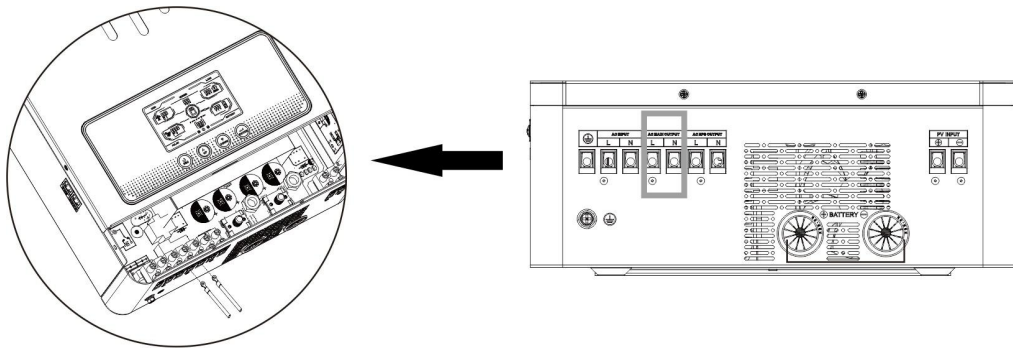

5. Then, insert the AC output conductor according to the polarity mark at the terminal, and tighten the screw. (Note: this road is connected to emergency standby load)

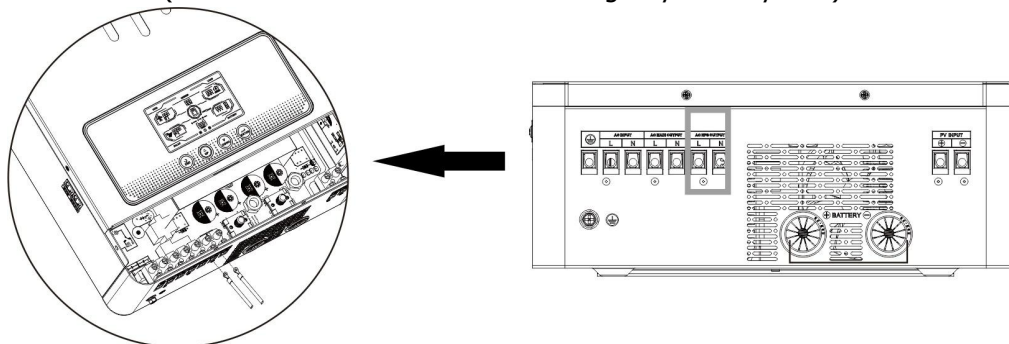

6. Make sure the wires are firmly connected.



CAUTION: Please ensure that all AC cables are connected correctly according to the corresponding polarity.



CAUTION: Appliances such as air conditioner are required at least 2~3 minutes to restart because it's required to have enough time to balance refrigerant gas inside of circuits. If a power shortage occurs and recovers in a short time, it will cause damage to your connected appliances. To prevent this kind of damage, please check manufacturer of air conditioner if it's equipped with time-delay function before installation. Otherwise, this inverter will trig overload fault and cut off output to protect your appliance but sometimes it still causes internal damage to the air conditioner.

PV Connection

CAUTION: Before connecting the PV module, please install separately a DC circuit breaker between the inverter and PV module.

WARNING! ! All wiring must be performed by a qualified personnel.

WARNING! ! It's very important for system safety and efficient operation to use appropriate cable for PV module connection. To reduce risk of injury, please use the proper recommended cable size as below.

Model	Wire Gauge	Torque Value
4.2KVA-24V	1 * 12 AWG	1.2-1.6 Nm
7KVA-48V	1 * 12 AWG	1.2-1.6 Nm

PV Module Selection:

When selecting proper PV modules, please be sure to consider below parameters:

1. Open circuit Voltage (Voc) of PV modules not exceeds max. PV array open circuit voltage of inverter.
2. Open circuit Voltage (Voc) of PV modules should be higher than min battery voltage.

Model	4.2KVA-24V	7KVA-48V
PV open circuit voltage	450Vdc	
MPPT operating voltage range	55Vdc~430Vdc	

Take 250Wp PV module as an example. After considering above two parameters, the recommended module configurations are listed as below table:

Solar panel parameters -250Wp -Vmp: 30.1Vdc -Imp: 8.3A -Voc: 37.7Vdc -Isc: 8.4A -Cells: 60	Solar Input	Q'ty of panels	Total Input
	Range (Min in serial: 6 pcs, max in serial: 11 pcs)		
	6 pcs in serial	6	1500W
	8 pcs in serial	8	2000W
	11 pcs in serial	11	2750W
	8 pieces in serial and 2 sets in parallel	16	4000W
	11 pieces in serial and 2 sets in parallel	22	5500W
	8 pieces in serial and 3 sets in parallel	24	6000W

3. Equipment Assembly

Please follow below steps to implement PV module connection:

- 1) Remove insulation sleeve 10 mm for positive and negative conductors.
- 2) Check correct polarity of connection cable from PV modules and PV input connectors. Then, connect positive pole (+) of connection cable to positive pole (+) of PV input connector. Connect negative pole (-) of connection cable to negative pole (-) of PV input connector.

3) Make sure the wires are securely connected.

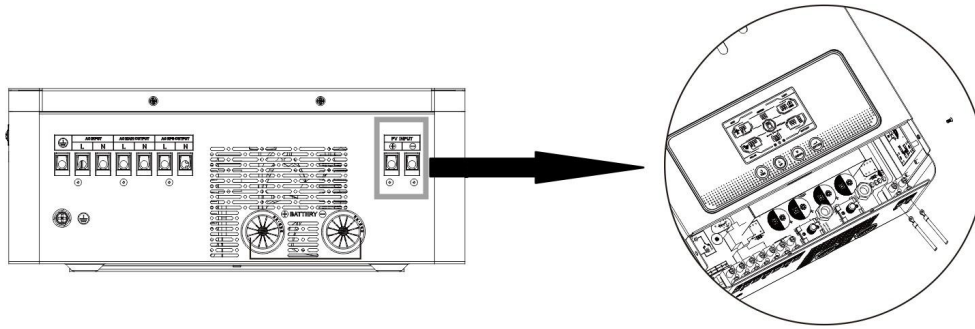

Final Assembly

After connecting all the wires, put the bottom cover back and screw the screws.

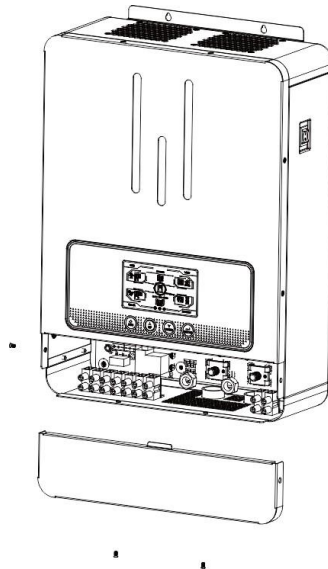

OPERATION

Power On/Off

After installing the machine correctly and connecting the battery correctly, just press the On/Off switch to turn on the machine.

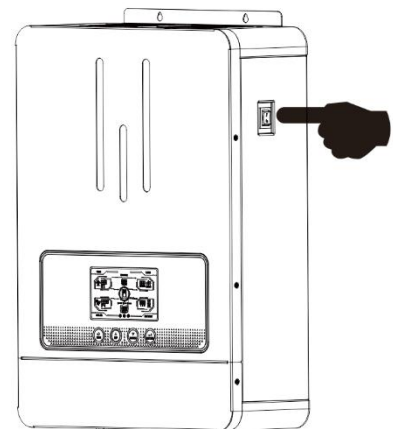

Operation And Display

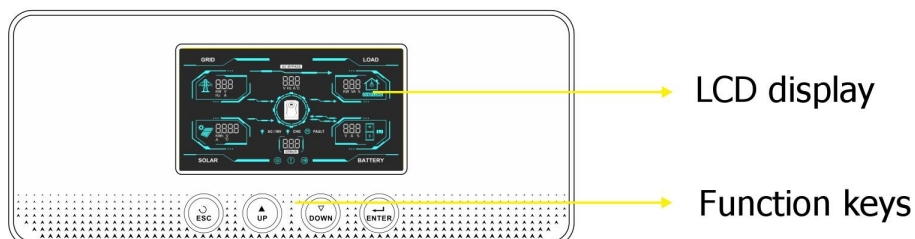

The operation and display panel is shown in the following figure, which is located on the front panel of the inverter. It includes four function keys and an LCD screen for indicating operation status and input/output power information.



RGB Light (optional)

Inverter state: green light
 Utility state: blue light
 Failure state: red light



Status Indicator













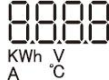

Status Indicator Icon	Indicating Information	
 AC / INV	Solid On	Output is powered by utility in Line mode
	Flashing	In battery mode, the output is powered by battery or PV
 CHG	Solid On	The battery is fully charged
	Flashing	The battery is charging
 FAULT	Solid On	Fault occurs in the inverter
	Flashing	Warning condition occurs in the inverter

Function Key

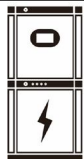
Function Keys	Description
ESC	Exit setup mode
UP	Skip to the previous setting.
DOWN	Jump to the next setting.
ENTER	Confirm the selected mode or enter the set mode.

Icon Of LCD Display

Icon	Functional Description
AC input information	
	AC input
 KW V Hz A	Indicate AC input voltage, AC input frequency

	Indicates load is supplied by utility power
PV input information	
	PV input
	Indicate PV input power, PV input voltage and PV input current.
Output information	
	Inverter
	Indicate output voltage, output frequency, output current and machine temperature.
Load information	
	Load
	Indicate load power, load percentage
	Indicate overload
Battery information	
	Battery
	Indicate battery voltage, battery current and battery capacity percentage.
	Lithium battery
Configuration program and fault information	
	Setup program
	Indicate warning code
	Indicate fault code
	Indicate alarm sound off

LCD Setting

After pressing and holding "ENTER" button for 3 seconds, the unit will enter setting mode. Press "UP" or "DOWN" button to select setting programs. And then, press "ENTER" button to confirm the selection or "ESC" button to exit.

Setting Programs:

Option	Describe	Optional Item
--------	----------	---------------

00	Exit setting mode	Escape 00 ESC	
01	Output source priority: To configure load power source priority	SUB priority (default) 01 SUB	Solar energy gives priority to supplying power to the load. If solar energy can't effectively provide all connected loads, Utility will provide power to the loads at the same time.
		SBU priority 01 SBU	Solar energy gives priority to supplying power to the load. If solar energy cannot effectively provide all connected loads, the battery will supply power to the loads at the same time. Utility provides power to the loads only when battery voltage drops to either low-level warning voltage or the setting point in program 12.
02	Maximum charging current: To configure total charging current for solar and utility chargers.	10A 02 10 ^A	20A 02 20 ^A
		30A 02 30 ^A	40A 02 40 ^A
		50A 02 50 ^A	60A 02 60 ^A
		70A 02 70 ^A	80A (default) 02 80 ^A
		90A 02 90 ^A	100A 02 100 ^A
		110A 02 110 ^A	
03	Ac input voltage range	Appliances (default) 03 APL	If selected, acceptable AC input voltage range will be within 90-280VAC.
		UPS 03 UPS	If selected, acceptable AC input voltage range will be within 170-280VAC.
04	Power saving mode enable/disable	Saving mode disable(default) 04 SDS	If disabled, no matter connected load is low or high, the on/off status of inverter output will not be effected.
		Saving mode enable 04 SEN	If enabled, the output of inverter will be off when connected load is pretty low or not detected.
		AGM (default)	Flooded

05	Battery type	05 <u>AGn</u>	05 <u>FLd</u>
		User-Defined 05 <u>USE</u>	LIB 05 <u>LIB</u>
		LIB-485 LIB 05 <u>485</u>	If USE or LIB is selected, battery charge voltage and low DC cut-off voltage can be set up in program 26, 27 and 29.
06	Auto restart when overload occurs	Restart disable(default) 06 <u>LTd</u>	Restart enable 06 <u>LTE</u>
07	Auto restartwhen over temperature occurs	Restart disable(default) 07 <u>ETd</u>	Restart enable 07 <u>ETE</u>
08	Output voltage	220V 08 <u>220^v</u>	230V (default) 08 <u>230^v</u>
		240V 08 <u>240^v</u>	
09	Output frequency	50Hz (default) 09 <u>50</u>	60Hz 09 <u>60</u>
10	Lithium battery protocol	PYLON (default) 10 <u>PYL</u>	PACE 10 <u>PAC</u>
11	Maximum Utility charging current	10A 11 <u>10^A</u>	20A 11 <u>20^A</u>
		30A 11 <u>30^A</u>	40A 11 <u>40^A</u>
		50A 11 <u>50^A</u>	60A (default) 11 <u>60^A</u>
		70A 11 <u>70^A</u>	80A 11 <u>80^A</u>
		90A 11 <u>90^A</u>	100A 11 <u>100^A</u>
12	Setting voltage point back to utility source when selecting "SBU priority"	Available options in 24V models:	
		22V 12 <u>220^v</u>	22.5V 12 <u>225^v</u>
		23V (default) 12 <u>230^v</u>	23.5V 12 <u>235^v</u>
		24V	24.5V

		12 <u>240</u> ^v	12 <u>245</u> ^v
		25V 12 <u>250</u> ^v	25.5V 12 <u>255</u> ^v
		Available options in 48V models:	
		44V 12 <u>44</u> ^v	45V 12 <u>45</u> ^v
		46V (default) 12 <u>46</u> ^v	47V 12 <u>47</u> ^v
		48V 12 <u>48</u> ^v	49V 12 <u>49</u> ^v
		50V 12 <u>50</u> ^v	51V 12 <u>51</u> ^v
13	Setting voltage point back to battery mode when selecting "SBU priority" in program 01	Available options in 24V models:	
		Battery full charged 13 <u>FUL</u>	24V 13 <u>240</u> ^v
		24.5V 13 <u>245</u> ^v	25V 13 <u>250</u> ^v
		25.5V 13 <u>255</u> ^v	26V 13 <u>260</u> ^v
		26.5V 13 <u>265</u> ^v	27V (default) 13 <u>270</u> ^v
		27.5V 13 <u>275</u> ^v	28V 13 <u>280</u> ^v
		28.5V 13 <u>285</u> ^v	29V 13 <u>290</u> ^v
		Available options in 48V models:	
		Battery full charge 13 <u>FUL</u>	48V 13 <u>480</u> ^v
		49V 13 <u>490</u> ^v	50V 13 <u>500</u> ^v
		51V 13 <u>510</u> ^v	52V 13 <u>520</u> ^v
		53V 13 <u>530</u> ^v	54V (default) 13 <u>540</u> ^v
		55V 13 <u>550</u> ^v	56V 13 <u>560</u> ^v
		57V	58V

		13 570 ^v	13 580 ^v
16	Charger source priority: To configure charger source priority	If this inverter/charger is working in Line, Standby or Fault mode, charger source can be programmed as below:	
		Solar first 16 C50	Solar energy will charge battery as first priority. Utility will charge battery only when solar energy is not available.
		Solar and Utility(default) 16 5NU	Solar energy and utility will charge battery at the same time.
		Only Solar 16 050	Solar energy will be the only charger source no matter utility is available or not.
		If this inverter/charger is working in Battery mode or Power saving mode, only solar energy can charge battery. Solar energy will charge battery if it's available and sufficient.	
18	Alarm control	Alarm on (default) 18 60N	Alarm off 18 60F
19	Auto return to default display screen	Return to default display screen(default) 19 ESP	If selected, no matter how users switch display screen, it will automatically return to default display screen (Input voltage /output voltage) after no button is pressed for 1 minute.
		Stay at latest screen 19 FEP	If selected, the display screen will stay at latest screen user finally switches.
20	Backlight control	Backlight on(default) 20 LON	Backlight off 20 LOF
22	Beeps while primary source is interrupted	Alarm on (default) 22 AON	Alarm off 22 AOF
23	Overload bypass: When enabled, the unit will transfer to line mode if overload occurs in battery mode.	Bypass disable (default) 23 byd	Bypass enable 23 byE
25	Record fault code	Record enable 25 FEN	Record disable(default) 25 FdS
26	Bulk charging voltage (C.V voltage)	Default setting of 24V model: 28.2V C4 26 28.2 ^v	
		Default setting of 48V model: 56.4V C4 26 56.4 ^v	
		If USE or LIB is selected in program 5, this program can be set up. Set voltage range, 24V model: from 24V to 29.2V; 48V Model: from 48.0V to 58.4V, and each press increases	

		by 0.1V.	
27	Floating charging voltage	Default setting of 24V model: 27.0V <u>FLV</u> 27 <u>270^v</u>	
		Default setting of 48V model: 54.0V <u>FLV</u> 27 <u>540^v</u>	
		If USE or LIB is selected in program 5, this program can be set up. Set voltage range, 24V model: from 24V to 29.2V; 48V Model: from 48.0V to 58.4V, and each press increases by 0.1V.	
29	Low DC cut-off voltage	Default setting of 24V model: 21.0V <u>COV</u> 29 <u>210^v</u>	
		Default setting of 48V model: 42.0V <u>COV</u> 29 <u>420^v</u>	
		If USE or LIB is selected in program 5, this program can be set up. set voltage range, 24V model: from 20V to 24V; 48V models range from 40V to 48V, Increment of each click is 0.1V. Low DC cut-off voltage will be fixed to setting value no matter what percentage of load is connected.	
33	Battery equalization	Battery equalization <u>33</u> <u>EEV</u>	Battery equalization disable(default) <u>33</u> <u>EdS</u>
		If "Flooded" or "User-Defined" is selected in program 05, this program can be set up.	
34	Battery equalization voltage	Default setting of 24V model: 29.2V <u>EV</u> 34 <u>292^v</u>	
		Default setting of 48V model: 58.4V <u>EV</u> 34 <u>584^v</u>	
		The setting range of 24V model is from 25.0V to 29.5V, and 48V model is from 50V to 59.0V . Increase by 0.1V per press.	
35	Battery equalized time	60min (default) <u>35</u> <u>60</u>	Setting range is from 5 min to 900min. Increment of each click is 5min.
36	Battery equalized timeout	120min (default) <u>36</u> <u>120</u>	Setting range is from 5min to 900 min. Increment of each click is 5min.
37	Equalization interval	30 days (default) <u>37</u> <u>30d</u>	Setting range is from 0 to 90 days. Increment of each click is 1 day
39	Equalization activated immediately	Enable <u>39</u> <u>AEV</u>	Disable(default) <u>39</u> <u>AdS</u>
		If equalization function is enabled in program 33, this program can be set up. If "Enable" is selected in this program, it's to activate battery equalization immediately and LCD mainpage will shows "Eq". If "Disable" is selected, it will cancel equalization function until next activated equalization time arrives based on program 37 setting. At this time, "" will not be shown in LCD main page.	

40	Setting time: year	Year 2023 40	Default:2023 Setting Range:2023~2099
41	Setting time: month	Moon 00 41 7	Default:01 Setting Range:01~12
42	Setting time: day	Day day 42 25	Default:01 Setting Range:01~31
43	Setting time: hour	Hour HOU 43 9	Default:00 Setting Range:00~23
44	Setting time: minutes	minute n 10 44 46	Default:00 Setting Range:01~59
45	Setting time: seconds	second SEC 45 55	Default:00 Setting Range:01~59
46	AC Charge time setting	0000 (default) Allow the mains to charge all day. CHG 61 n 0000 46	There are four numbers used to describe the AC charge time setting. The two numbers in left is start time. Setting Range:00~23 And the other two numbers in right is time of end. Setting Range:00~23 (For example, 2320 means that the mains charge time are 23:00 to the next day 20:59)
47	AC input to power Load time setting	0000 (default) Allow the mains to be loaded all day. OUP 61 n 0000 47	There four numbers used to describe the utility to take load time setting. The two numbers in left is start time. Setting Range:00~23 And the other two numbers in right is time of end. Setting Range:00~23 (For example, 2320 means that the utility to take load time are 23:00 to the next day 20:59)
48	RGB lighting	RGB lights 48 L0F off	RGB lights on (default) 48 L0n
49	Dual output	Disable (default) 49 L2F	Enable 49 L2n If you select Enable in the program, the inverter will turn off the main output when the battery is low The inverter will not restore the main output until the battery voltage returns to the 13 set point
50	Grid-Connected	Disable (default)	Enable

	50 0Fd	50 0FE	If enabled is selected in the program, the PV energy is preferentially satisfied with battery charging, and the rest of the energy is returned to the grid
--	--------	--------	--

LCD Display Information

By pressing the "UP" or "DOWN" key, the information on the LCD screen will be switched in turn. Optional information is switched in the following order: voltage, frequency, current, power, firmware version and time.

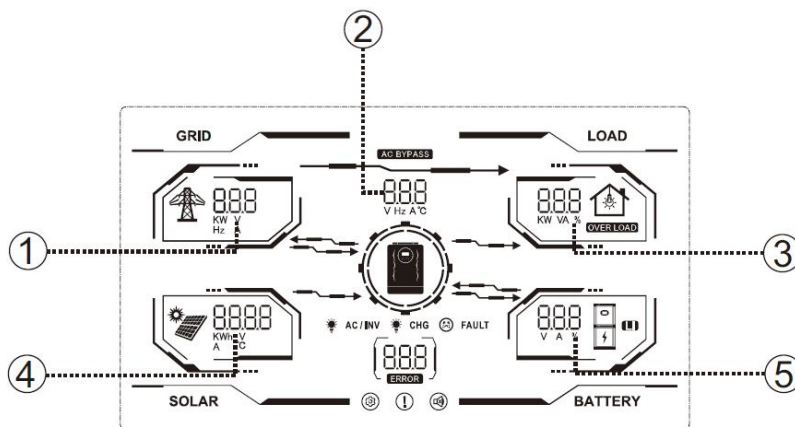

Parameter Information	LCD display
<ul style="list-style-type: none"> ① AC input voltage ② Output voltage ③ Load percentage ④ PV input voltage ⑤ Battery voltage (Default interface) 	
<ul style="list-style-type: none"> ① AC input frequency ② Output frequency ③ Load power VA ④ PV input current ⑤ Battery voltage 	





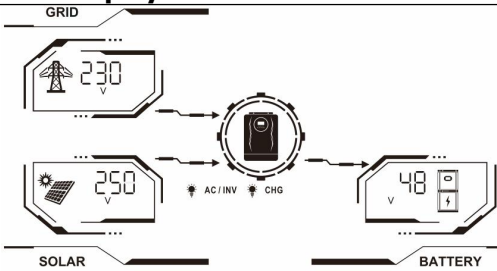
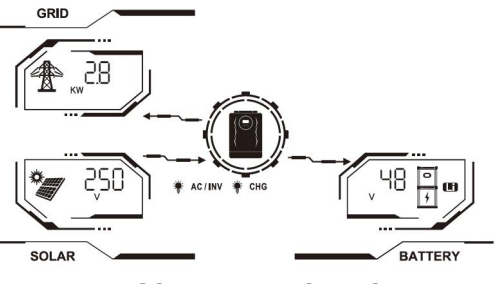
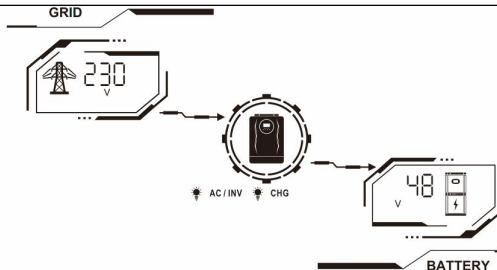
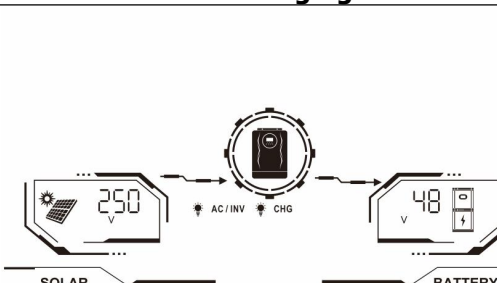
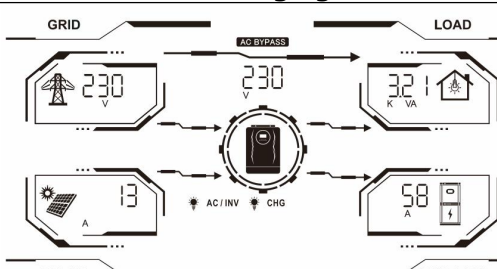

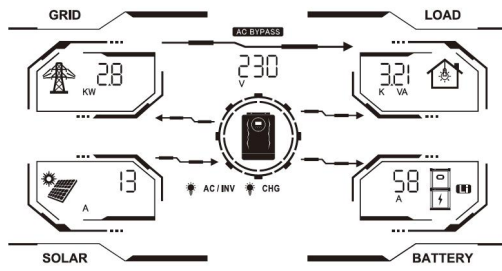
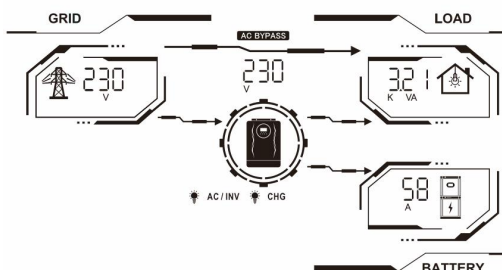
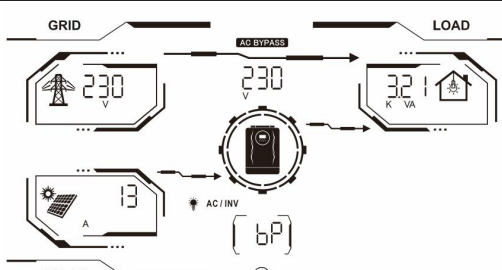
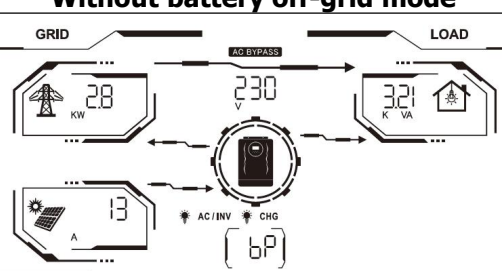
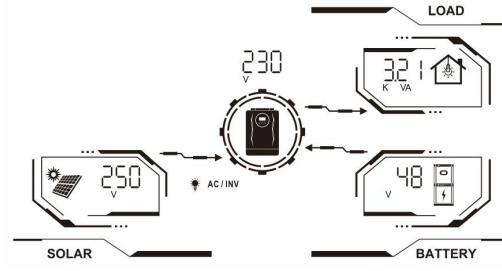
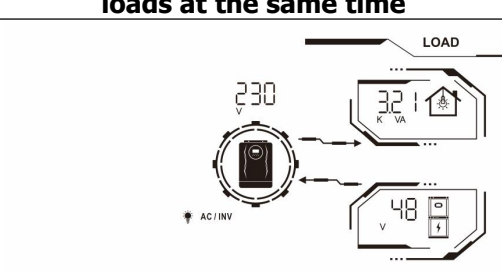







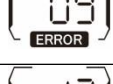

<ul style="list-style-type: none"> ① AC input voltage ② Output voltage ③ Load power W ④ PV input power ⑤ Battery charging current 	<p>Dashboard showing: GRID (230V), AC BYPASS (230V), LOAD (108KW), SOLAR (2.2KW), and BATTERY (36.6A). Indicators for AC/INV and CHG are visible.</p>
<ul style="list-style-type: none"> ① AC input frequency ② Machine temperature ③ Output current ④ Solar total yielding KWh ⑤ Battery charging current 	<p>Dashboard showing: GRID (50Hz), AC BYPASS (3.14°C), LOAD (12.4A), SOLAR (5.2KWh), and BATTERY (6.8A). Indicators for AC/INV and CHG are visible.</p>
<ul style="list-style-type: none"> ③ The solar total yielding in a recent month. (as shown is 8.8KWh) ④ The solar total yielding in a recent year. (as shown is 28.83KWh) ⑤ The solar total yielding in a recent day. (as shown is 3.6KWh) 	<p>Dashboard showing: 8.8 KWh (month), 28.83 KWh (year), and 3.6 KWh (day). A central battery icon is also present.</p>
<p>Firmware version (CPU: SR-57-00)</p>	<p>Dashboard showing: 57-00. A central battery icon is also present.</p>
<p>Time (2023-7-26, 15:35:06)</p>	<p>Dashboard showing: 15:35, 2023-07-26. A central battery icon is also present.</p>

Operation Mode Description

Operator Schema	Explain	LCD Display
<p>Stand bymode/ Power saving mode Note: *Standby mode: The inverter is not turned on yet but at this time, the inverter can charge battery without AC output. *Power saving mode: If enabled, the output of inverter will be off when connected load is pretty low or not detected.</p>	<p>No output is supplied by the unit but it still can charge batteries.</p>	 <p>PV and mains charging</p>
		 <p>Grid-connected mode</p>
		 <p>Mains charging</p>
		 <p>PV charging</p>
		 <p>solar and mains supply power to loads at the same time</p>

<p>Line Mode</p>	<p>The unit will provide output power from the mains. It will also charge the battery at line mode.</p>	 <p>Grid-connected mode</p>  <p>Mains charging</p>  <p>Without battery off-grid mode</p>  <p>Without battery Grid-connected mode</p>
<p>Battery Mode</p>	<p>The unit will provide output power from battery and PV power.</p>	 <p>Battery and Solar supply power to loads at the same time</p>  <p>Battery supply power to loads</p>

Fault Code

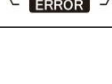
Fault Code	Fault Event	Icon on
01	Fan is locked when the inverter is turned off.	
02	Over temperature	
03	Battery voltage is too high	
04	Battery voltage is too low	
05	Output short circuit or over temperature.	
06	Output voltage is too high	
07	Exceeding overload time	
08	BUS voltage is too high	
09	BUS soft start failed.	
13	PV voltage is too high	
51	Over current and surge	
52	BUS voltage is too low	
53	Inverter soft start failed.	
55	Over DC voltage in AC output	
56	Battery is disconnected	
57	Current sensor failed.	
58	Output voltage is too low	

Warning code

Warning Code	Warning Event	Automatic Alarm	Icon flashing
01	Fan is locked when inverter is on.	Beep three times every second	[01] ⓘ
03	Battery overcharge	Beep once every second	[03] ⓘ
04	Battery low voltage	Beep once every second	[04] ⓘ
07	Overload	Beep once every 0.5 second	[07] ⓘ
10	Output power is derating	Beep twice every 3 seconds	[10] ⓘ
15	PV energy is weak	No Beep	[15] ⓘ
EQ	Battery equalization	No Beep	[E9] ⓘ
bP	Battery is not connected.	No Beep	[bP] ⓘ

BATTERY EQUALIZATION

Equalization function is added into charge controller. It reverses the buildup of negative chemical effects like stratification, a condition where acid concentration is greater at the bottom of the battery than at the top. Equalization also helps to remove sulfate crystals that might have built up on the plates. If left unchecked, this condition, called sulfation, will reduce the overall capacity of the battery. Therefore, it's recommended to equalize battery periodically.

- How to Apply Equalization Function

You must enable battery equalization function in monitoring LCD setting program 33 first. Then, you may apply this function in device by either one of following methods:

1. Setting equalization interval in program 37.
2. Active equalization immediately in program 39.

- When to Equalize

In float stage, when the setting equalization interval (battery equalization cycle) is arrived, or equalization is active immediately, the controller will start to enter Equalize stage.

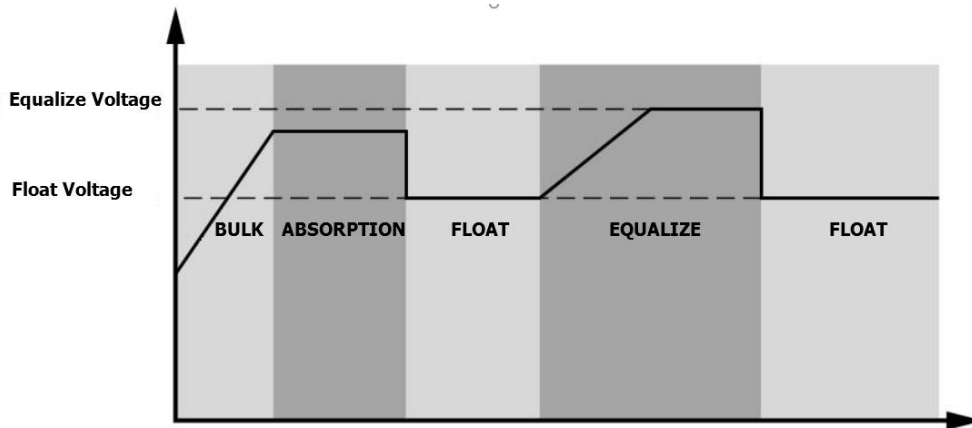

- Equalize charging time and time out

In equalize stage, the controller will supply power to charge battery as much as possible until battery voltage rises to battery equalization voltage. Then, constant voltage regulation is applied to maintain battery voltage at the battery equalization voltage. The battery will remain in the Equalize stage until setting battery equalized time is arrived.

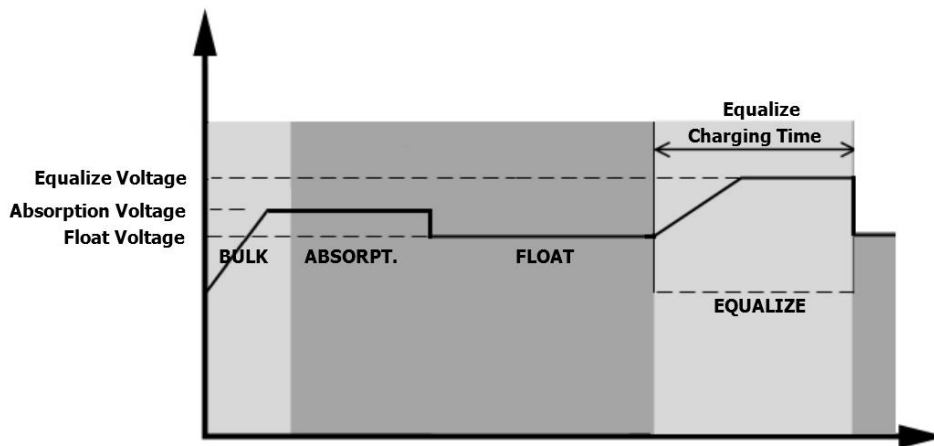

However, in Equalize stage, when battery equalized time is expired and battery voltage doesn't rise to battery equalization voltage point, the charge controller will extend the battery equalized time until battery voltage achieves battery equalization voltage. If battery voltage is still lower than battery equalization voltage when battery equalized time out setting is over, the charge controller will stop equalization and return to float stage.

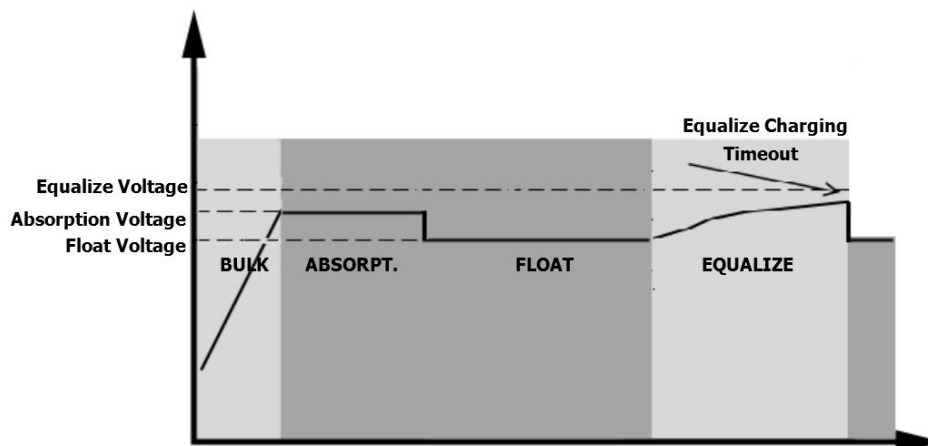

SPECIFICATIONS

Table 1 Specification of LINE Mode

INVERTER MODEL	4.2KVA 24V	4.2KVA 48V	7KVA 48V
Input Voltage Waveform	Sinusoidal (utility or generator)		
Nominal Input Voltage	230Vac		
Low Loss Voltage	170Vac±7V (UPS) 90Vac±7V (Appliances)		
Low Loss Return Voltage	180Vac±7V (UPS); 100Vac±7V (Appliances)		
High Loss Voltage	280Vac±7V		
High Loss Return Voltage	270Vac±7V		
Max AC Input Voltage	300Vac		
Nominal Input Frequency	50Hz / 60Hz (Auto detection)		
Low Loss Frequency	40±1Hz		
Low Loss Return Frequency	42±1Hz		
High Loss Frequency	65±1Hz		
High Loss Return Frequency	63±1Hz		
Output Short Circuit Protection	Battery mode: Electronic Circuits		
Efficiency (Line Mode)	>95% (Rated R load, battery full charged)		
Transfer Time	10ms typical(UPS); 20m stypical(Appliances)		
<p>Output power derating: When AC input voltage drops to 95V or 170V depending on models, the output power will be derated.</p>	<p>The graph illustrates the output power derating characteristics. The vertical axis represents Output Power, and the horizontal axis represents Input Voltage. Key points on the graph include: <ul style="list-style-type: none"> At 90V input voltage, the output power is 50% of the rated power. Between 90V and 170V, the output power increases linearly to reach the full Rated Power. From 170V to 280V, the output power remains constant at the Rated Power level. At 280V, the output power drops to zero. </p>		

Table 2 Specification of Inverter Mode

INVERTER MODEL	4.2KVA 24V	4.2KVA 48V	7KVA 48V
Rated Output Power	3800W		6200W
Output Voltage Waveform	Pure Sine Wave		
Output Voltage Regulation	230Vac±5%		
Output Frequency	60Hz or 50Hz		
Peak Efficiency	94%		
Overload Protection	5s@≥150% load;10s@110%~150% load		
Surge Capacity	2* rated power for 5 seconds		
Nominal DC Input Voltage	24Vdc	48Vdc	
Cold Start Voltage	23.0Vdc	46.0Vdc	
Low DC Warning Voltage			
@ Load < 20%	22.0Vdc	44.0Vdc	
@ 20% ≤ Load < 50%	21.4Vdc	42.8Vdc	
@ Load ≥ 50%	20.2Vdc	40.4Vdc	
Low DC Warning Return Voltage			
@ Load < 20%	23.0Vdc	46.0Vdc	
@ 20% ≤ Load < 50%	22.4Vdc	44.8Vdc	
@ Load ≥ 50%	21.2Vdc	42.4Vdc	
Low DC Cut-off Voltage			
@ Load < 20%	21.0Vdc	42.0Vdc	
@ 20% ≤ Load < 50%	20.4Vdc	40.8Vdc	
@ Load ≥ 50%	19.2Vdc	38.4Vdc	
High DC Recovery Voltage	29Vdc	58Vdc	
High DC Cut-off Voltage	31Vdc	62Vdc	
No Load Power Consumption	<25W	<50W	
Saving Mode Power Consumption	<10W	<15W	

Table 3 Double Load Output Power

Inverter Type	4.2KVA 24V	4.2KVA 48V	7KVA 48V
Fully Loaded	3800W		6200W
Maximum Load Of Main Road	3800W		6200W
Maximum Load Of Emergency Power Supply(BATTY MODE)	1200W		2000W
Main output cut-off voltage	22V	44V	
Main output recovery voltage	27V	54V	

(consistent with program 13 setting)

Table 4 Specification of Charging Mode

Utility Charging Mode			
INVERTER MODEL	4.2KVA 24V	4.2KVA 48V	7KVA 48V
Charging Current(UPS) @Nominal Input Voltage	100A	60A	100A
Bulk Charging Voltage	Flooded Battery	29.2	58.4
	AGM / Gel Battery	28.2	56.4
Floating Charging Voltage	27Vdc	54Vdc	
Charging Algorithm	3-Step		
Charging Curve	<p>The graph plots Battery Voltage (per cell) on the left y-axis and Charging Current (%) on the right y-axis against Time on the x-axis. The voltage curve (black line) rises linearly in the Bulk stage, plateaus in the Absorption stage, and then slightly drops and remains constant in the Maintenance stage. The current curve (red line) is constant in the Bulk stage, then decays exponentially in the Absorption stage, and remains very low in the Maintenance stage. Key voltage points are 2.43Vdc (2.35Vdc) and 2.25Vdc. Time intervals T0 and T1 are marked, with T1 = 10 * T0, minimum 10mins, maximum 8hrs.</p>		
Solar Charging Mode			
INVERTER MODEL	4.2KVA 24V	4.2KVA 48V	7KVA 48V
Rated Power	6000W		
Rated Solar Voltage	300V		
PV Array MPPT Voltage Range	55V-430V		
Max. PV Array Open Circuit Voltage	450V		
Max Charging Current	110A	80A	110A

Table 5 General specifications

INVERTER MODEL	4.2KVA 24V	4.2KVA 48V	7KVA 48V
Operating Temperature Range	0°C to 55°C		

Storage temperature	-15°C~ 60°C		
Dimension (D*W*H), mm	423*300*120		
Net Weight, kg	7.7	8.0	8.4

TROUBLE SHOOTING

Problem	LCD/Buzzer	Explanation / Possible cause	What to do
Unit shuts down automatically during startup process.	LCD and buzzer will be active for 3 seconds and then complete off.	Battery voltage is too low	1. Re-charge battery. 2. Replace battery.
No response after power on.	No indication.	1. The battery voltage is far too low. 2. Battery polarity is connected reversed.	1. Check if batteries and the wiring are connected well. 2. Re-charge battery. 3. Replace battery.
Mains exist but the unit works in battery mode.	Input voltage is displayed as 0 on the LCD	Input protector is tripped	Check if AC breaker is tripped and AC wiring is connected well.
	The power-on icon of LCD flashes, and the status indicator icon flashes.	Insufficient quality of AC power. (Shore or Generator)	1. Check if AC wires are too thin and/or too long. 2. Check if generator (if applied) is working well or if input voltage range setting is correct. (UPS→Appliance)
Buzzer beeps continuously and the status indicator icon is always on.	Fault code 07	Overload error. The inverter is overload 110% and time is up.	Reduce the connected load by switching off some equipment.
	Fault code 05	Output short circuited.	Check if wiring is connected well and remove abnormal load.
	Fault code 02	Internal temperature of inverter component are over heated.	Check whether the air flow of the unit is blocked or whether the ambient temperature is too high.
	Fault code 03	Battery is over-charged.	Return to repair center.
		The battery voltage is too high.	Check if spec and quantity of batteries are meet requirements.
	Fault code 01	Fan fault	Replace the fan
	Fault code 06/58	Output abnormal	1. Reduce the connected load. 2. Return to repair center
	Fault code 08/09/53/57	Internal components failed.	Return to repair center.
	Fault code 51	Over current or surge.	Restart the unit, if the error happens again, please return to repair center.
Fault code 52	Bus voltage is too low.		
Fault code 55	Output voltage is unbalanced.		